

V I  N T O

# V I N T O

**IT**

Presentiamo con entusiasmo la nostra esclusiva Zanzariera Avvolgente Laterale a Molla pensata per le grandi aperture, una soluzione elegante e altamente funzionale progettata per offrire la massima protezione e comfort.

---

**FR**

C'est avec enthousiasme que nous présentons notre exclusive moustiquaire enroulable latéral à ressort conçue pour les grandes ouvertures, une solution élégante et hautement fonctionnelle pensée pour offrir une protection et un confort maximums.

---

**EN**

We are very happy to present you our exclusive side roll Fly Screen designed for large openings: an elegant, high-performance solution created to offer maximum protection and comfort.

---

**DE**

Wir präsentieren voller Begeisterung unser einzigartiges seitliches Rollo mit Federmechanismus für große Öffnungen. Es ist eine elegante und hochfunktionelle Lösung, die maximalen Schutz und Komfort bietet.

# V I N T O

Ecco i punti salienti che la rendono unica:

Here are the features that make it unique:

Voici les points forts qui la rendent unique:

Nachfolgend sind die Höhepunkte, die es einzigartig machen:



## Ideale per Ampie Aperture

Ideal for Large Openings

Idéale pour les grande ouvertures

Ideal für große Öffnungen

Ideale per spazi ampi, la zanzariera VIENTO può coprire aperture fino a 3000 mm per singola anta e addirittura 6000 mm con due ante, offrendo una soluzione flessibile e adattabile alle esigenze di ampie vetrate.

Our Fly Screen VIENTO can cover widths up to 3000 mm for a single door, and even 6000 mm for double doors, offering a flexible and adaptable solution for large windows.

Idéale pour les grands espaces, la moustiquaire VIENTO peut couvrir des ouvertures jusqu'à 3000 mm avec un seul vantail et 6000 mm avec deux vantaux, tout en offrant une solution flexible et adaptable aux grandes fenêtres.

Das VIENTO ist ideal für große Räume und kann Öffnungen von bis zu 3000 mm mit einem Flügel und sogar 6000 mm mit zwei Flügeln abdecken. Es bietet eine flexible und anpassungsfähige Lösung für große Fenstertüren.



## Fettuccia e Bottoncini Antivento

Webbing and Windproof Buttons

Sangle et boutons coupe-vent

Gitterband und winddichte Druckknöpfe

La presenza di fettuccia e bottoncini antivento garantisce che la rete non fuoriesca dalle guide laterali, offrendo una protezione affidabile anche in presenza di vento forte.

Our mesh is electronically welded at sides and equipped with windproof buttons to prevent it from slipping out of the rails, offering reliable protection even in case of strong wind.

La présence de sangles et de boutons coupe-vent garantit que la moustiquaire ne glisse pas hors des guides latérales, en offrant ainsi une protection fiable même en cas de fort vent.

Die Ausstattung von Band und winddichten Druckknöpfen sorgt dafür, dass das Gitter nicht aus den seitlichen Schienen auskommt und bietet auch bei starkem Wind zuverlässigen Schutz.



## Resistenza al Vento con Sistema Antivento

Windproof System

Résistance au vent grâce

au Système Coupe-vent

Windwiderstand mit winddichtem System

Dotata di un avanzato sistema antivento, la zanzariera è progettata per resistere alle raffiche di vento, garantendo un utilizzo sicuro e duraturo.

Thanks to its advanced windproof system, our Fly Screen Viento is engineered to withstand gusts of wind, ensuring safe and durable use.

Équipée d'un système coupe-vent avancé, la moustiquaire est conçue pour résister aux rafales de vent, en garantissant ainsi une utilisation sûre et durable.

Es ist mit einem fortschrittlichen winddichten System ausgestattet und ist so konzipiert, dass es Windstöße standhält und eine sichere und dauerhafte Nutzung gewährleistet.



## Design Uniforme con Binari da 28mm

Harmonised design with 28 mm rails

Design uniforme avec des rails de 28 mm

Einheitliches Design mit 28 mm hohen Schienen

Il binario inferiore, uguale a quello superiore con un'altezza di 28 mm, offre un'estetica uniforme e moderna, integrandosi armoniosamente con il vano finestra.

Lower and upper rails are both 28 mm high, to offer an harmonious and modern design, perfectly integrated with your window.

Le rail inférieur, qui est identique au rail supérieur avec une hauteur de 28 mm, offre un aspect uniforme et moderne, s'intégrant harmonieusement au tableau de la fenêtre.

Die untere Schiene, die gleich hoch wie die obere Schiene ist, bietet eine einheitliche und moderne Ästhetik und harmonisiert perfekt mit der Fensterleibung.



## **Senso di Apertura**

### **Personalizzabile**

**Customizable Direction of Opening**  
**Sens d'ouverture personnalisable**  
**Anpassbare Öffnungsrichtung**

La possibilità di scegliere il senso di apertura durante il montaggio conferisce un'ulteriore flessibilità, adattando la zanzariera alle tue preferenze e alle caratteristiche dello spazio.

You have maximum freedom and flexibility to choose the direction of opening during installation.

La possibilité de choisir le sens d'ouverture lors du montage offre une flexibilité supplémentaire, en adaptant la moustiquaire à vos préférences et aux caractéristiques de l'espace.

Die Möglichkeit, die Öffnungsrichtung während der Montage zu wählen, bietet zusätzliche Flexibilität, um das Fliegengitter an Ihre Vorlieben und die Eigenschaften der Leibung anzupassen.



## **Chiusura Magnetica con Terminale**

**Magnetic Lock and Terminal profile**  
**Fermeture magnétique avec terminal**  
**Magnetischer Verschluss**

La chiusura magnetica garantisce una chiusura completa, permettendo di mantenere saldamente ancorata la maniglia al terminale grazie alla presenza del magnete.

The magnetic lock provides a full closure, allowing you to keep the handle-bar firmly secured to the terminal profile.

La fermeture magnétique garantit une fermeture complète, tout en permettant à la poignée d'être fermement ancrée au profil terminal grâce à la présence d'un aimant.

Der Magnetverschluss gewährleistet einen vollständigen Verschluss und ermöglicht das Griffprofil dank des Magneten fest am Endprofil zu halten.



## **Protezione PLUS contro Cimici**

### **e Altri Insetti:**

**Extra Protection against Bugs and Other Insects**  
**Protection PLUS contre les punaises et autres insectes**  
**PLUS Schutz gegen Wanzen und andere Insekten**

Oltre alla difesa standard contro le zanzare, la nostra zanzariera offre una protezione avanzata contro cimici e altri insetti, creando un ambiente sicuro e salutare.

In addition to the regular defense against mosquitoes, our Fly Screen Viento offers advanced protection against bugs and other insects, for a safe and healthy environment.

En plus de la protection standard contre les moustiques, notre moustiquaire offre une protection avancée contre les punaises et autres insectes, en créant ainsi un environnement sûr et sain.

Zusätzlich zum Standardschutz gegen Moskitos bietet unser Fliegengitter einen erweiterten Schutz gegen Wanzen und andere Insekten. Es schafft daher einen sicheren und gesunden Lebensraum.



Apertura  
Fino a **3 metri**

Opening up to **3 meters**  
Ouverture jusqu'à **3 mètres**  
Öffnung bis zu **3 meter**



V I  N T O

1 Anta / Shutter / Vantail / Flügel

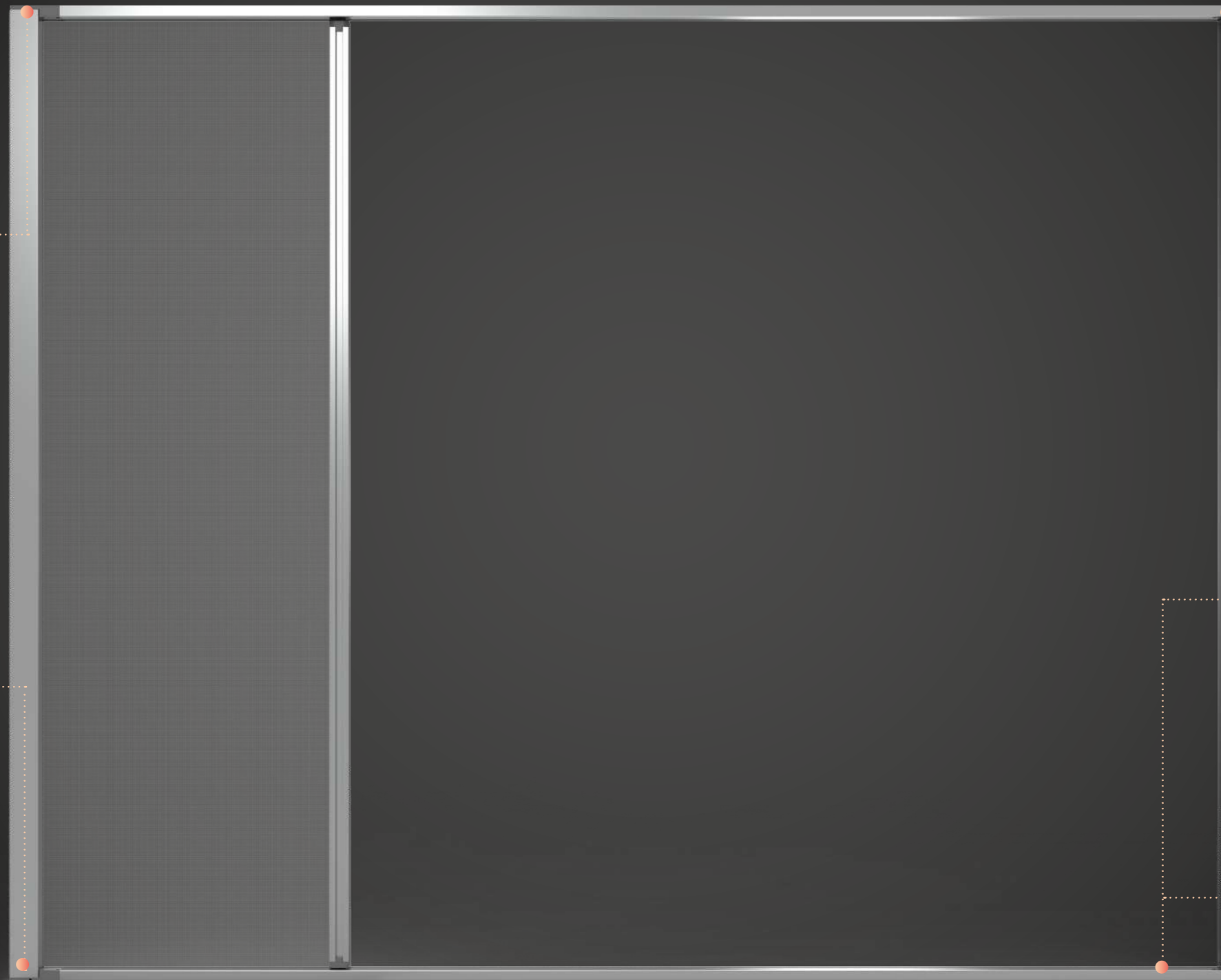
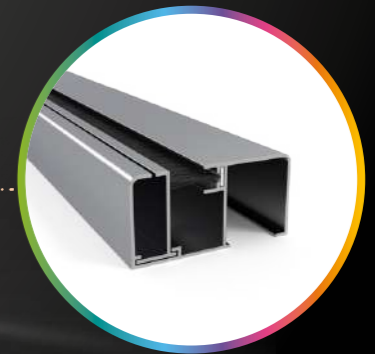
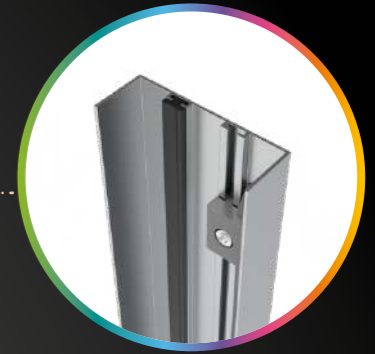
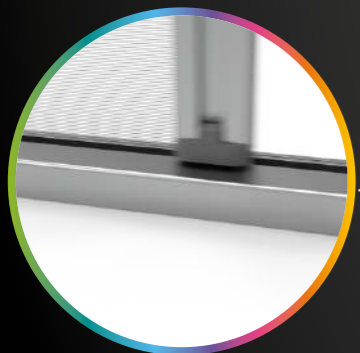



Apertura  
fino a **6 metri**

Opening up to **6 meters**

Ouverture jusqu'à **6 mètres**

Öffnung bis zu **6 meter**



V I  N T O

2 Ante / Shutters / Vantaux / Flügel

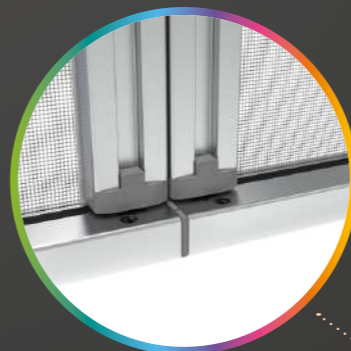
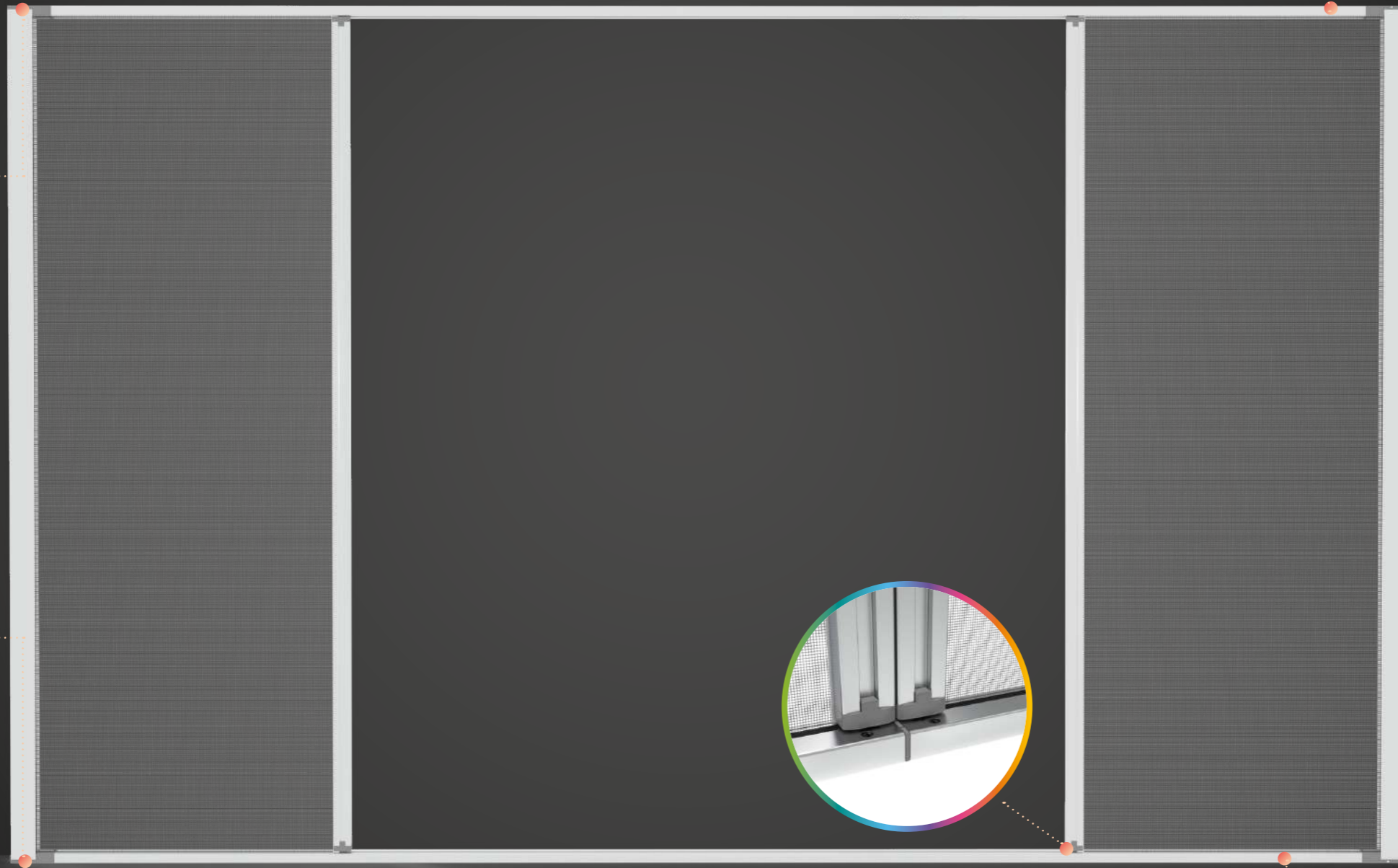



# VINTO

## Zanzariera Avvolgente Laterale a Molla

Side Roll Fly Screen

Moustiquaire à enroulement latéral à ressort

Seitliches Rollo mit Federmechanismus



**Apertura massima**  
Maximum opening  
Ouverture maximale  
Maximale Öffnung



**Chiusura magnetica**  
Magnetic lock  
Fermeture Magnétique  
Magnetverschluss

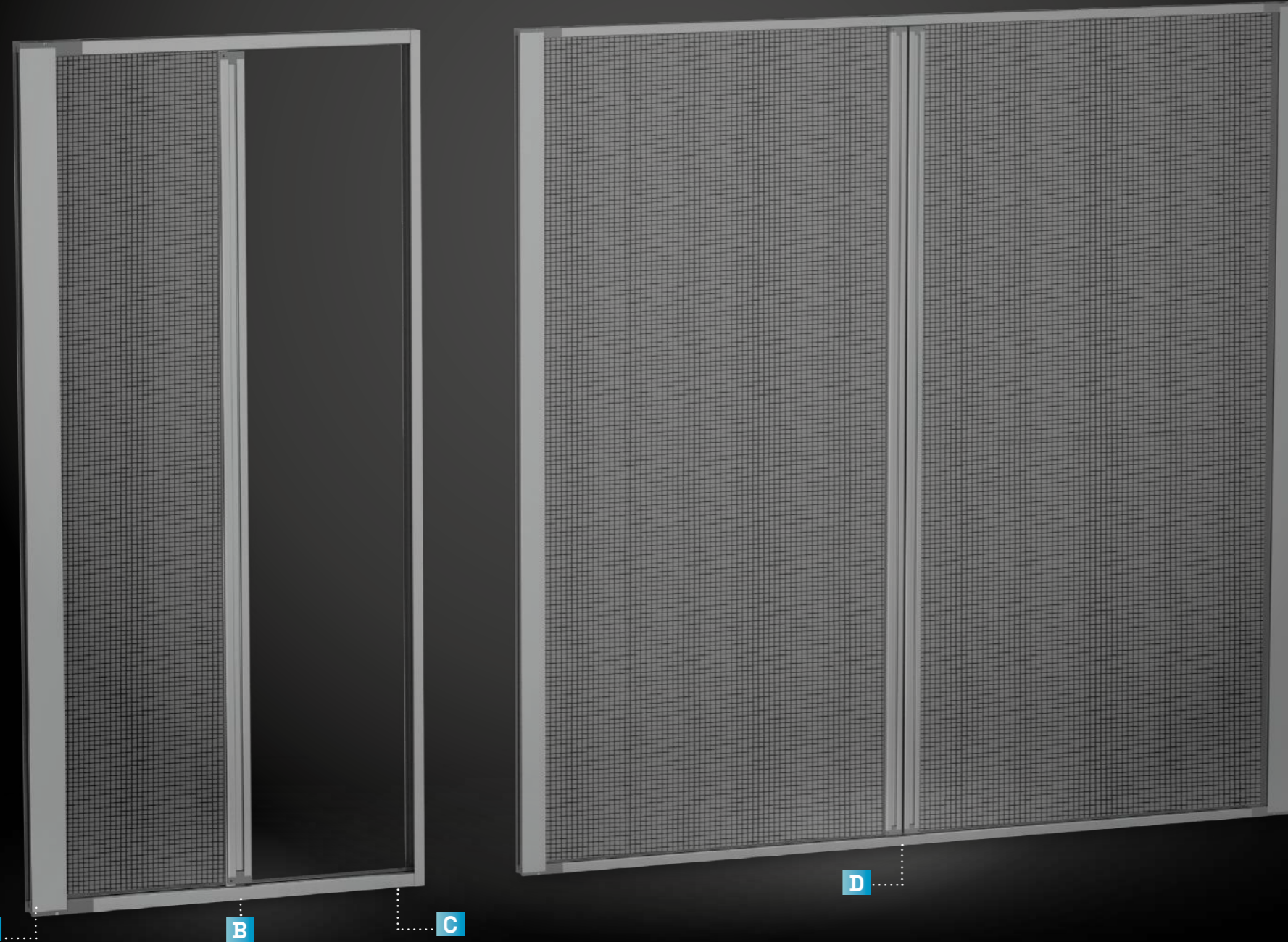

## Caratteristiche tecniche

Technical features / Caractéristiques techniques / Technische Details

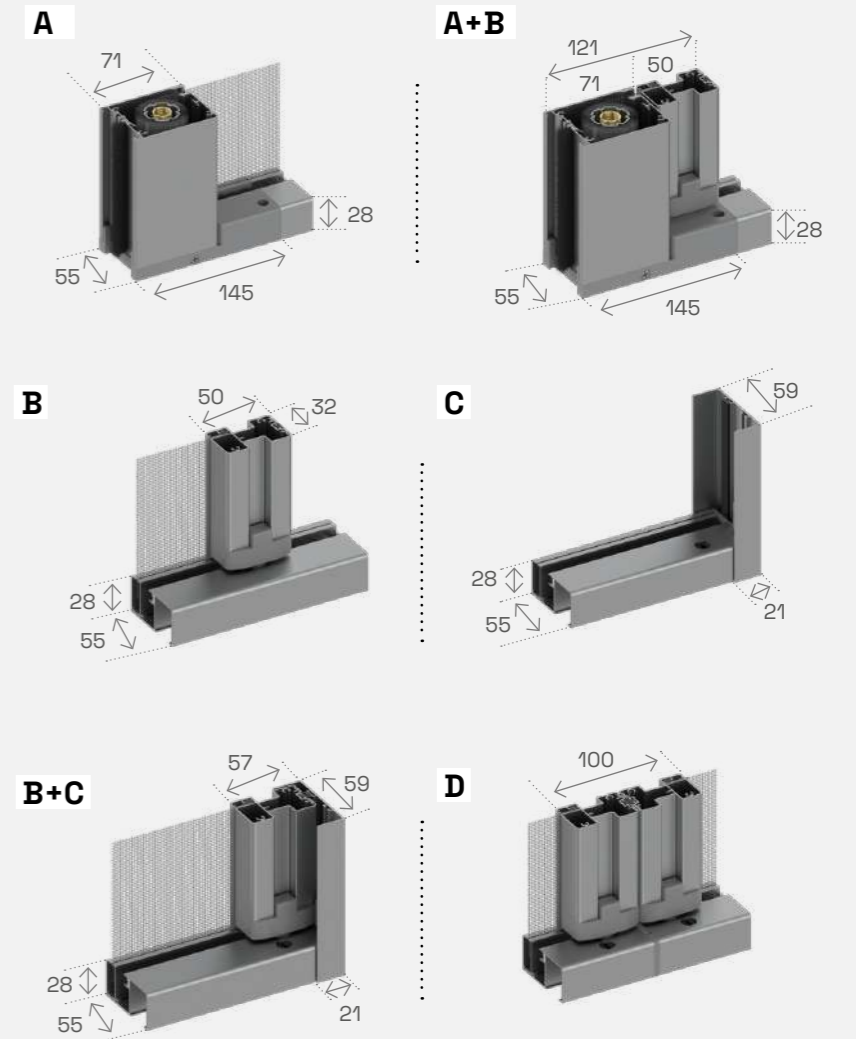

## Optional

**Profilo compensatore lato cassonetto**





U-profile on roller box side

Compensateur pour le caisson

Ausgleichprofil für Kasten

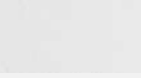
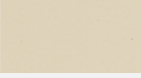





# Colori disponibili Colours / Couleurs / Farben

## Di serie Standard

					
<b>901</b> 9010 Bianco White Blanc Weiß	<b>9FG</b> 9010 Grinz Rough White Blanc Rugueux Grobes Weiß	<b>101</b> 1013 Avorio Ivory Ivoire Elfenbein	<b>F1G</b> 1013 Grinz Rough Ivory Ivoire Rugueux Grobes Elfenbein	<b>801</b> 8017 Marrone Brown Brun Braun	<b>MMU</b> Marrone Muschio Ruvido Rough Musk Brown Brun Mousse Grobes Moosbraun

## Accessori / Accessories / Accessoires / Zubehöre



 901	 901	 101	 101	 801	 801
---	---	---	---	---	---

					
<b>APR</b> Argento Verniciato Primed Painted Silver Argent Peint Silber lackiert	<b>71G</b> 7001 Grigio Grinz Rough Grey Gris Grinz Grobes Grau	<b>NOP</b> 9005 Nero Opaco Matt Black Noir Mat Schwarz Matt	<b>BVE</b> Bronzo Verniciato Painted Bronze Bronze Peint Bronze lackiert	<b>F35</b> Bronzo Scuro Dark Bronze Bronze Foncé Dunkelbronze	<b>60P</b> 6005 Verde Opaco Matt Green Vert mat Grün Matt

## Accessori / Accessories / Accessoires / Zubehöre

 OAX	 OAX	 OEL	 OBX	 OEL	 OEL
---	---	---	---	---	---





## Marmo Marble / Marbre / Marmorierte Farben

		
<b>GRA</b> Grigio Marmo Marble Grey Gris Marbre Marmoriertes Grau	<b>MRA</b> Marrone Marmo Marble Brown Brun Marbre Marmoriertes Braun	<b>VRA</b> Verde Marmo Marble Green Vert Marbre Marmoriertes Grün

## Accessori / Accessories / Accessoires / Zubehöre

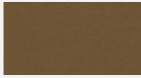
 OEL	 801	 OEL
---	---	---







## Speciali Special / Spéciales / Sonderfarben

				
<b>OBX</b> Bronzo Anodizzato Anodised Bronze Bronze Anodisé Bronze eloxiert	<b>OAX</b> Argento Anodizzato Anodised Silver Argent Anodisé Silber eloxiert	<b>GFS</b> Grigio ferro scuro Dark Iron Grey Gris Fer Foncé Dunkeleisengrau	<b>TMD</b> Testa di Moro Scuro Dark Brown Marron Foncé Dunkelbraun	<b>RBU</b> Rame Bugnato Hammered Copper Cuivre Gaufré Bossiertes Kupfer







## Accessori / Accessories / Accessoires / Zubehöre





 OBX	 OAX	 OEL	 OEL	 801
---	---	---	---	---

## Colori legno Wood / Bois / Holzfarben





					
<b>PCN</b> Ciliegio Natural Opaco Matt Natural Cherry Cerisier Naturel Mat Naturalkirschholz Matt	<b>D3R</b> Ciliegio Fiammato Ruvido Rough Shot Cherry Cerisier Flammé Rugueux Geflammtes grobes Naturalkirschholz	<b>C21</b> Ciliegio Fiammato Atlantico Shot Atlantic Cherry Cerisier Flammé Atlantique Geflammtes Atlantik Naturalkirschholz	<b>N10</b> Noce Ruvido Rough Walnut Noyer Rugueux Grobes Nussbaumholz	<b>PNS</b> Noce Scuro Natural Opaco Matt Dark Natural Walnut Noyer Foncé Naturel Mat Dunkles Naturalnussbaumholz Matt	<b>M37</b> Noce Scuro Ruvido Rough Dark Walnut Noyer Foncé Rugueux Dunkles grobes Nussbaumholz

## Accessori / Accessories / Accessoires / Zubehöre

 801	 801	 801	 801	 801	 801
---	---	---	---	---	---

			
<b>DR1</b> Renolit Chiaro Bright Renolit Renolit Clair Helles Renolit	<b>DRS</b> Renolit Scuro Dark Renolit Renolit Foncé Dunkles Renolit	<b>C24</b> Pino Nodoso Chiaro Bright Knotty Pine Pin Nouveux Clair Helles knorriges Kieferholz	<b>DBE</b> Bianco Legno White Wood Bois Blanc Holz Weiß

## Accessori / Accessories / Accessoires / Zubehöre

 801	 801	 801	 101
---	---	---	---

**Grigio**

Grey  
Gris  
Grau

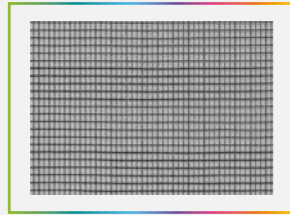

**Nero**

Black  
Noir  
Schwarz

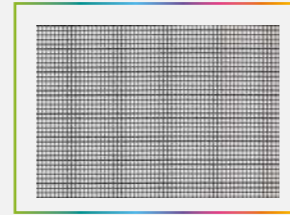

**Pet Screen Light Nero**

Thin black pet screen  
Pet Screen light noire  
Dünnes schwarzes  
Petscreen

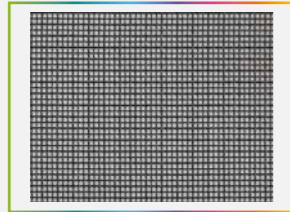

**Pet Screen Light Grigio**

Thin grey pet screen  
Pet Screen light grise  
Dünnes graues  
Petscreen

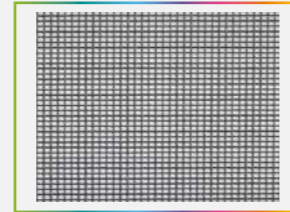

**Bianco/Nero**

White/Black  
Blanc/Noir  
Weiß/Schwarz

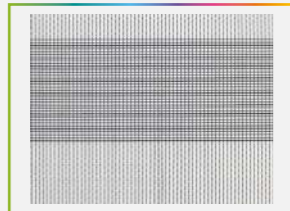

**Antipolline**

Anti-pollen mesh  
Toile Antipollen  
Anti-pollen Gewebe



**Telo in fibra sottile grigia**

Thin grey fibreglass  
mesh  
Toile en fibre fine grise  
Dünnes graues  
Fiberglasgewebe

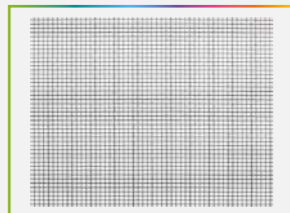

**Telo in fibra sottile nero**

Thin black fibreglass mesh  
Toile en fibre fine noire  
Dünnes schwarzes  
Fiberglasgewebe

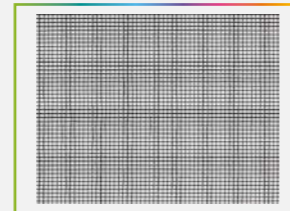

**Oscurante  
bianco-marrone**

White-brown blackout  
fabric  
Toile opaque  
blanche-marron  
Weiß-braunes  
Verdunkelungsgewebe

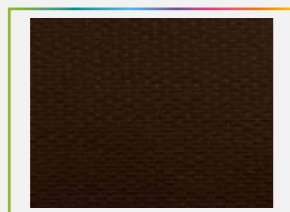

**Oscurante beige**

Beige blackout fabric  
Toile opaque beige  
Beiges  
Verdunkelungsgewebe

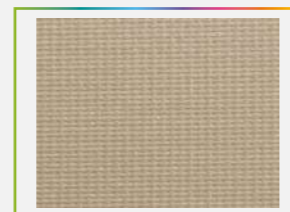

**Oscurante bianco**

White blackout fabric  
Toile opaque blanche  
Weißes  
Verdunkelungsgewebe

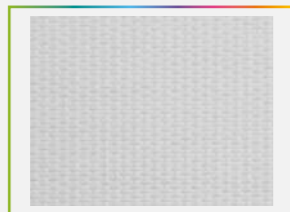

**Crystal**

**(trasparente)**  
Transparent Crystal fabric  
Toile PVC Cristal  
transparente  
Transparentes  
Crystalgewebe

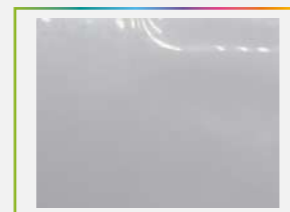

**Screen scuro**

Dark filtering screen  
Toile screen sombre  
Dunkles Filtergewebe

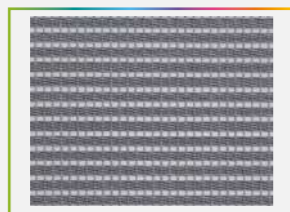

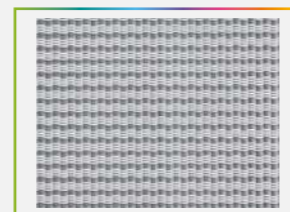

**Screen chiaro**

Light filtering screen  
Toile screen claire  
Helles Filtergewebe



**CONTACTS**

 Corso Europa, 9  
Grottaglie (TA) - ITALIA

 (+39) 099 5623969

 [commerciale@primed.it](mailto:commerciale@primed.it)  
[export@primed.it](mailto:export@primed.it)

PRIMED



primed.it

neverbeforeitalia.it